

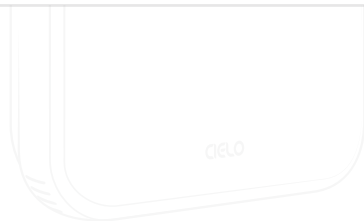

# Cielo Smart Thermostat **ECO**

## Installation Manual



Thanks for choosing Cielo for your  
home climate control!

Cielo Smart Thermostat Eco is designed and optimized  
to save energy while prioritizing comfort.

**Simple to Install | Easy to Use | Saves You Energy**

**Let's Start!**



## **Tools you need:**

Drill for mounting anchors (3/16" drill bit)

Small flathead screwdriver

Phillips screwdriver

Wire stripper (optional)

Hammer (optional)

Pencil (optional)

# Included in the box:



Cielo Smart Thermostat Eco

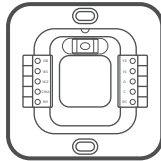

Thermostat Backplate

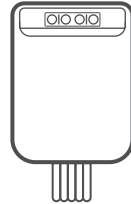

C-Wire Adapter

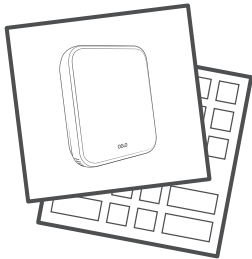

Installation Manual  
and Wire Labels

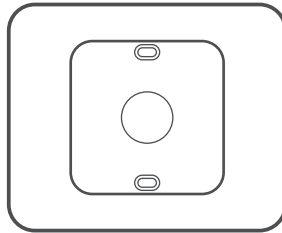

Thermostat Wall Plate

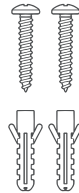

Mounting Screws With  
Drywall Anchors

# Getting Help

No long queues, no bots, no delays.  
We answer 98% calls in less than 2 minutes  
and guarantee that you will **talk to a REAL person.**

Visit our website: [cielowigle.com](https://cielowigle.com) and  
**select support to access user guides.**



Email us at:  
[support@cielowigle.com](mailto:support@cielowigle.com)

Call us at:  
**+1 (425) 529-5775**

**9 AM - 9 PM ET, Mon-Fri**

**Note:** The information and instructions in this manual are subject to change. For the latest details, please visit [support.cielowigle.com](https://support.cielowigle.com)



**Let's Install Your Thermostat**

# Step 1:

**Safety First** - Power off your HVAC system using:

- 1 The master switch  
OR
- 2 The circuit breaker

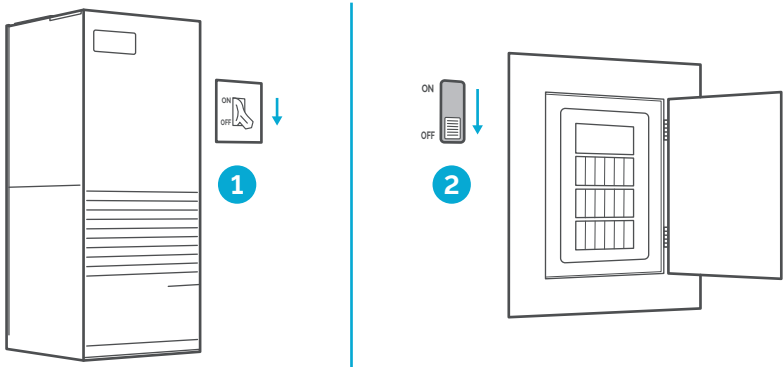

## Step 2:

To be on the safe side, **ensure that your system is completely switched off**. Double-check that:

- 1 No air is coming out of the air vents.

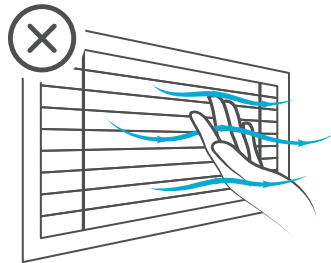
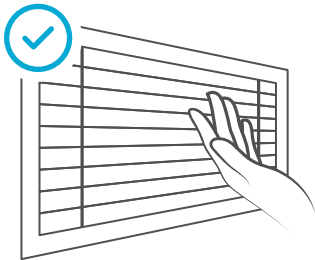

- 2 Main flame is extinguished in the case of a boiler.

## Step 3:

Go to your already installed thermostat and **remove it** from the wall.

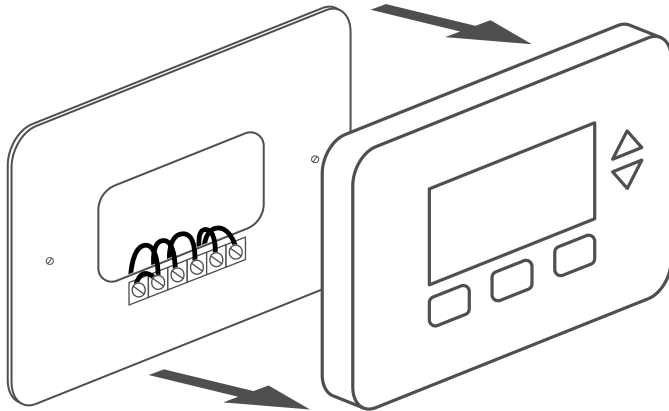

## Step 4:

Look closely for any of the following indicators on your old thermostat's backplate:

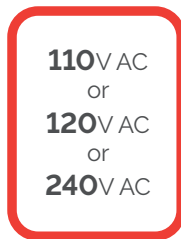
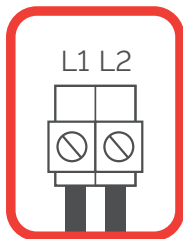

**If you find any of the above indicators, please contact Cielo Tech Support for assistance** (visit page 4 for contact details).

**In case of no such indicators, go to the next page.**

### **⚠ WARNING**

Cielo Smart Thermostat Eco only works with 24V AC.  
It does not work with line (high) voltage or millivolt systems.

## Step 5:

Grab your smartphone and **take a picture** of your old thermostat wiring.

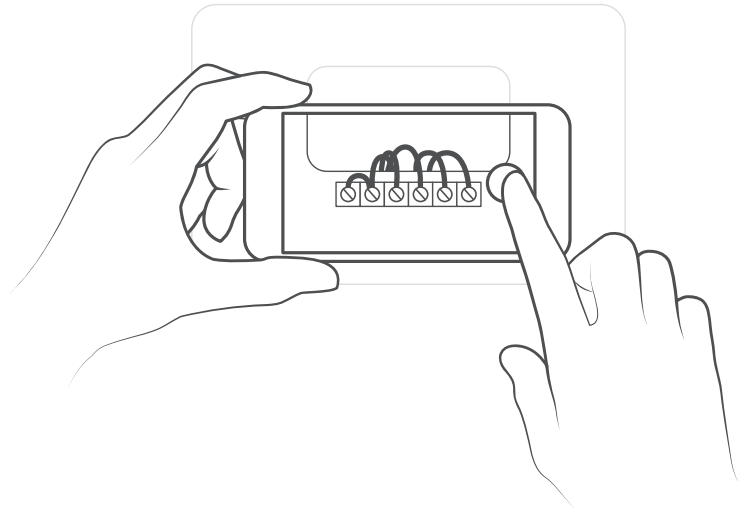

## Step 6:

Does your old thermostat have a  
**C-Wire connection?**

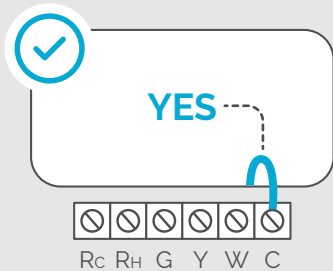

Continue to **Section 1**  
on next page

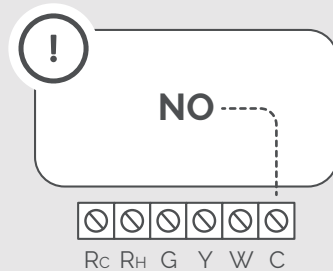

Continue to **Section 2**  
on page 22

## Section 1

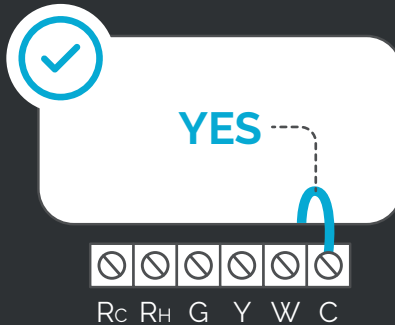

# Installing Your Cielo Smart Thermostat Eco With a C-Wire

## Step 7:

- 1 **Disconnect the old thermostat wires** one by one and mark them using the wire labels (included in the box).

Jumper wire is not required with your new thermostat.

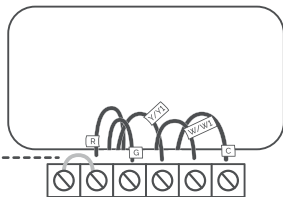

- 2 Remove the mounting plate of your old thermostat.

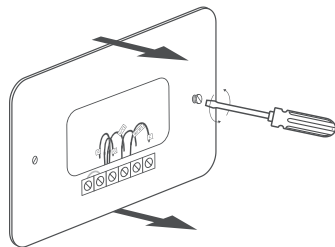

## Step 8:

**Optional:** You may use the provided wall plate to hide any marks or holes on the wall left by your old thermostat installation.

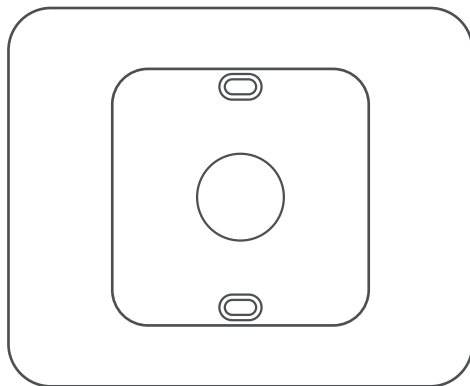

## Step 9:

- 1 Take out the labeled wires through the hole in the middle of the Cielo Smart Thermostat Eco backplate.
- 2 Screw in the backplate using the provided pair of drywall anchors and screws.

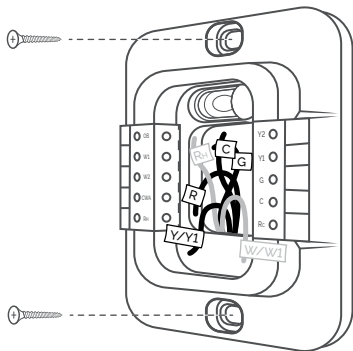

## Step 10:

Do you have more than one R-Wire?  
(That includes R, R<sub>c</sub>, and R<sub>H</sub>)

✓ YES

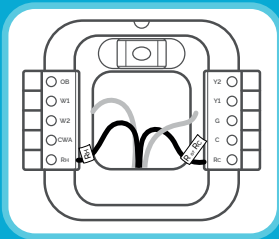

Insert your wires:  
R<sub>H</sub> → R<sub>H</sub>      R or R<sub>c</sub> → R<sub>c</sub>

✗ NO

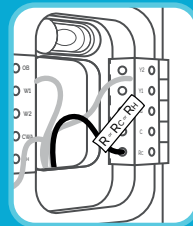

Insert your single  
R, R<sub>c</sub>, or R<sub>H</sub> wire into  
the **R<sub>c</sub>** terminal.

## Step 11:

**Insert the remaining wires** into their corresponding terminals from the side (press terminal block buttons for ease of insertion).

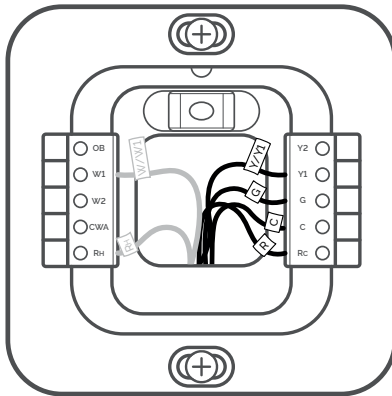

## Step 12:

Gently push the excessive wires back into the wall hole to ensure that no drafts are coming from it.

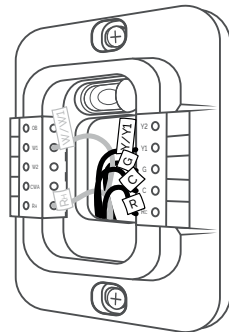
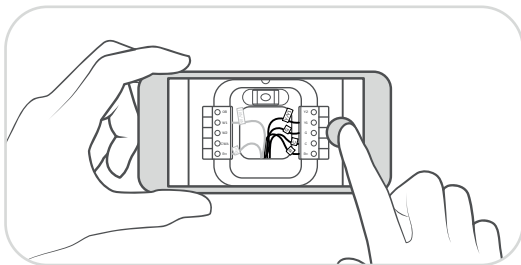

Take a picture of the backplate.  
**You may need it at the time of registration.**

## Step 13:

Align your **Cielo Smart Thermostat Eco** with the backplate and press gently to **fix it properly**.

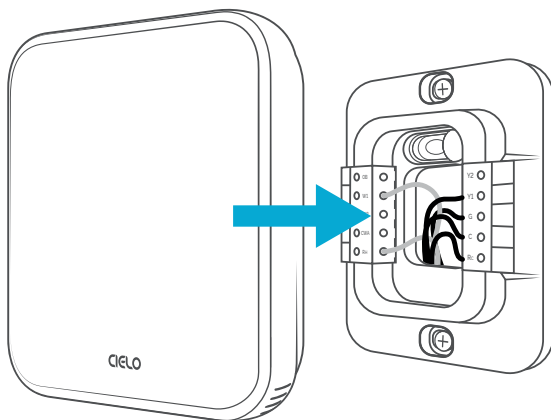

## Step 14:

Go to your HVAC system and turn on the power from the master switch or circuit breaker.

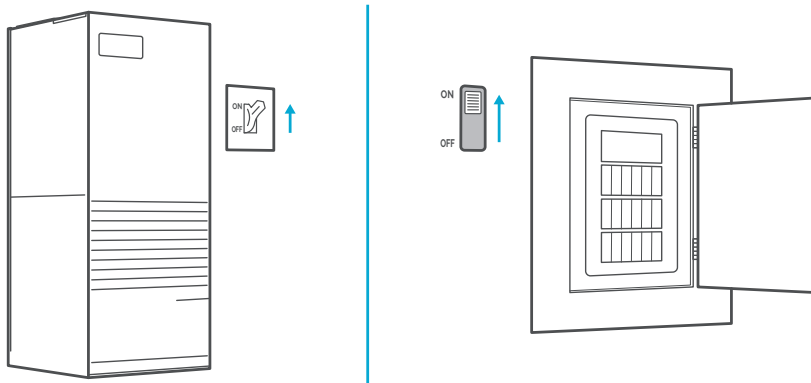

## **Installation Complete!**

Go to page 41 for steps  
to register your thermostat.

## Section 2

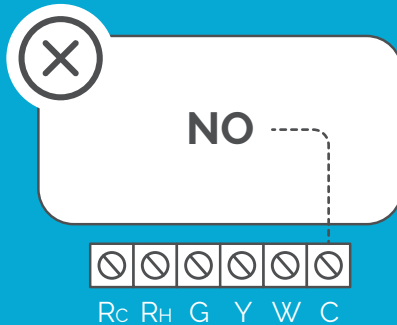

# Installing Your Cielo Smart Thermostat Eco Without a C-Wire

If your system has any of the following wires,  
**it should work with the C-Wire Adapter.**

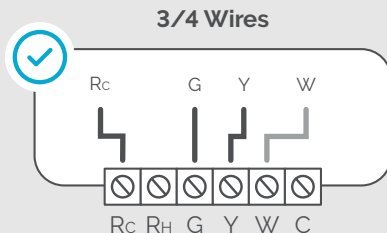
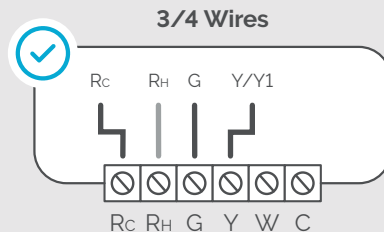
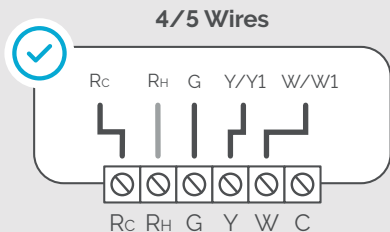

Please continue on page 25

If your system has these wires:

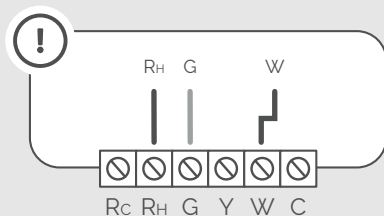

**Contact Cielo Tech Support;  
we will help you with the installation.**



Email us at: [support@cielowigle.com](mailto:support@cielowigle.com)

Call us at: **+1 (425) 529-5775**

**9 AM - 9 PM ET, Mon-Fri**

## Step 7:

Take out **the C-Wire Adapter (CWA)** from the Cielo Smart Thermostat Eco box.

(Ensure that you have already completed steps 1-5 of this guide)

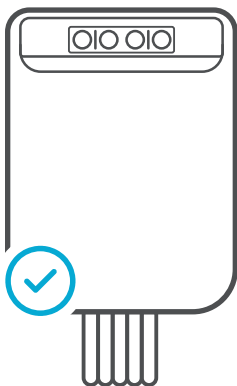

## Step 8:

Grab the C-Wire Adapter, wire labels, tools, your smartphone, and **go to your HVAC system.**

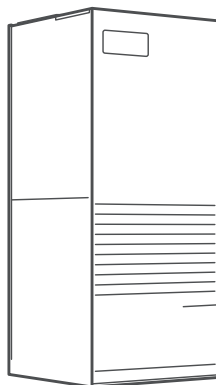

## Step 9:

Take off your HVAC system's cover to **access the control board and take a picture of the connected wires.** You may need it at a later stage.

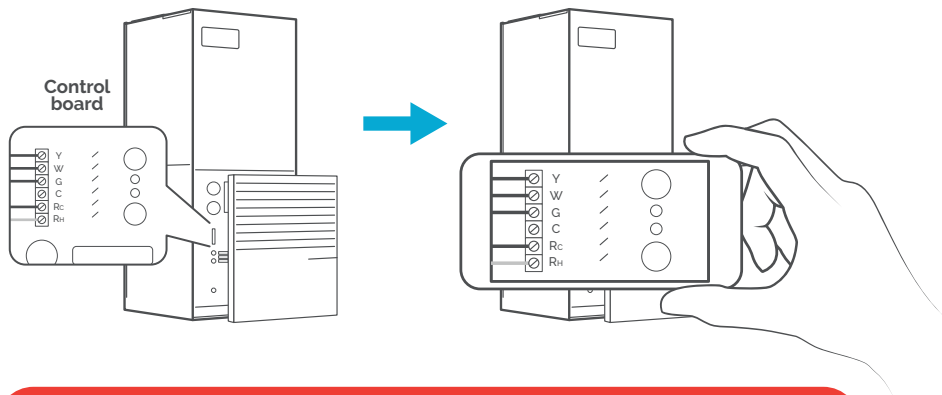

### WARNING

Proceed with caution, as HVAC systems contain high-voltage wires.

## Step 10:

Label only the following wires with the matching labels:

**R** - **Y or Y1** - **G** - **W or W1**

You only need to label the wires coming from your thermostat.

Ignore any extra wires going into the terminals.

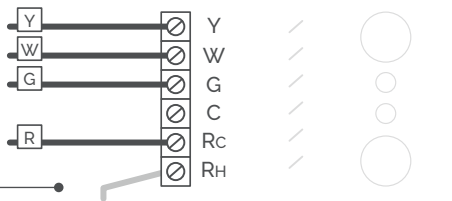

### Note:

In the case of a two-transformer system (wires connected to both Rc and Rh terminals at the control board), please contact Cielo Tech Support to help you with the installation. **Call:** +1 (425) 529-5775 **Email:** [support@cielowigle.com](mailto:support@cielowigle.com)

## Step 11:

**Disconnect** the labeled **R, Y, G,** and **W** wires from the control board.

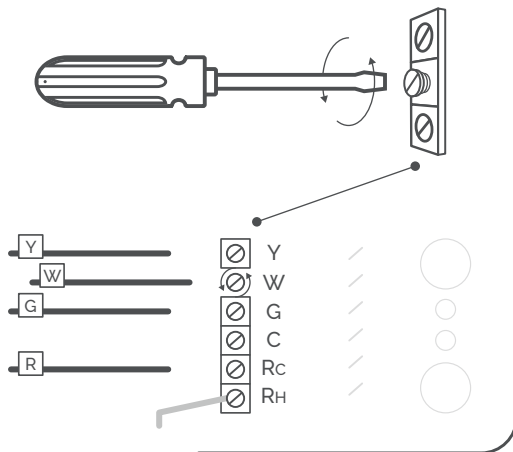

## Step 12:

**Securely connect the wires** from the control board  
**to their matching terminals** on the CWA.

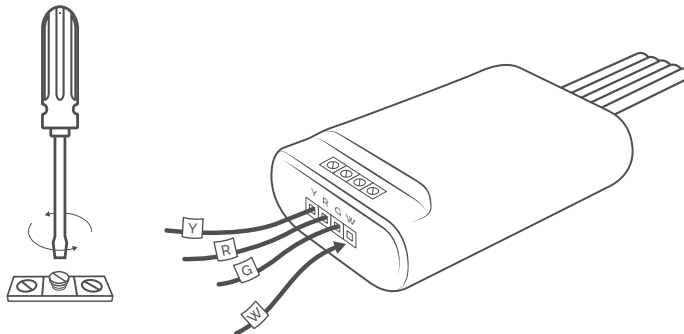

## Step 13:

**Securely connect all the wires** coming out of the C-Wire Adapter to the corresponding terminals on the control board of your HVAC system.

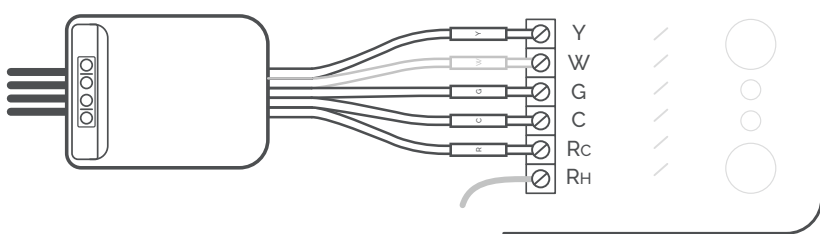

## Step 14:

Place/mount the CWA at a suitable location inside your HVAC system. Close the HVAC cover panel securely and **return to your old thermostat.**

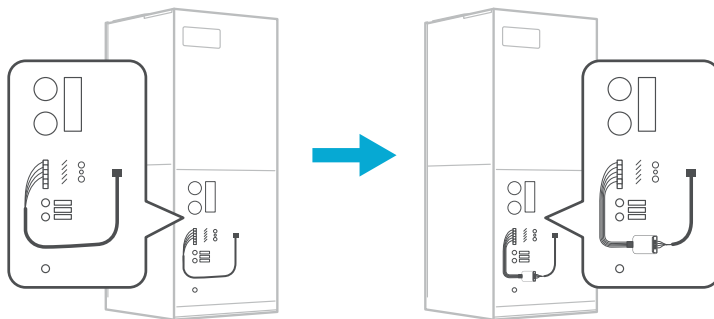

## Step 15:

- 1 **Disconnect the old thermostat wires** one by one and mark them using the wire labels (included in the box).

Jumper wire is not required with your new thermostat.

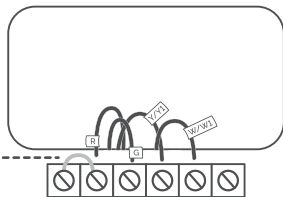

- 2 **Remove the mounting plate** of your old thermostat.

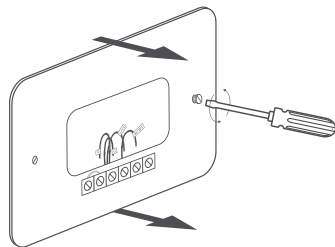

## Step 16:

**Optional:** You may use the provided wall plate to hide any marks or holes on the wall left by your old thermostat installation.

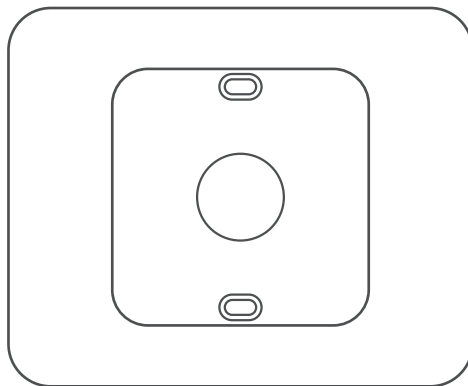

## Step 17:

- 1 Take out the labeled wires through the hole in the middle of the Cielo Smart Thermostat Eco backplate.
- 2 Screw in the backplate using the provided pair of drywall anchors and screws.

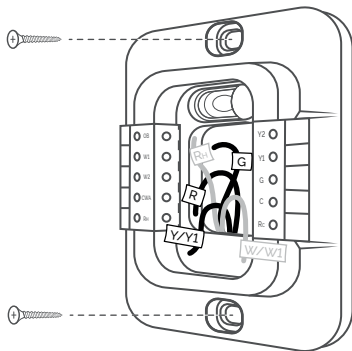

## Step 18:

First, connect these 3 wires as shown:

R/Rc → Rc

G → C

Y/Y1 → CWA

Then, connect the remaining wires to their corresponding terminals (press terminal block buttons for ease of insertion).

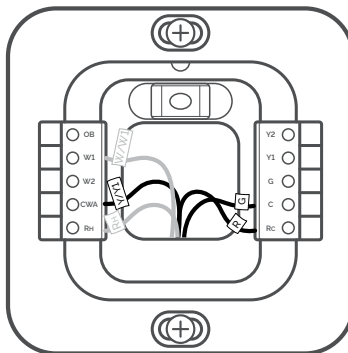

## Step 19:

Gently push the excessive wires back into the wall hole to ensure that no drafts are coming from it.

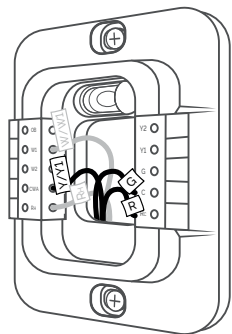
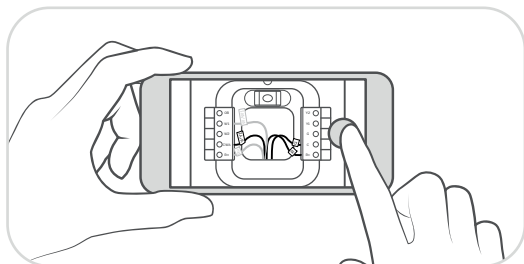

Take a picture of the backplate.  
**You may need it at the time of registration.**

## Step 20:

Align your **Cielo Smart Thermostat Eco** with the backplate and press gently to **fix it properly**.

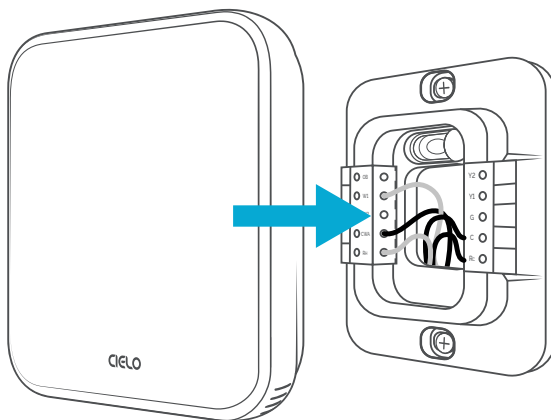

## Step 21:

Go to your HVAC system and turn on the power from the master switch or circuit breaker.

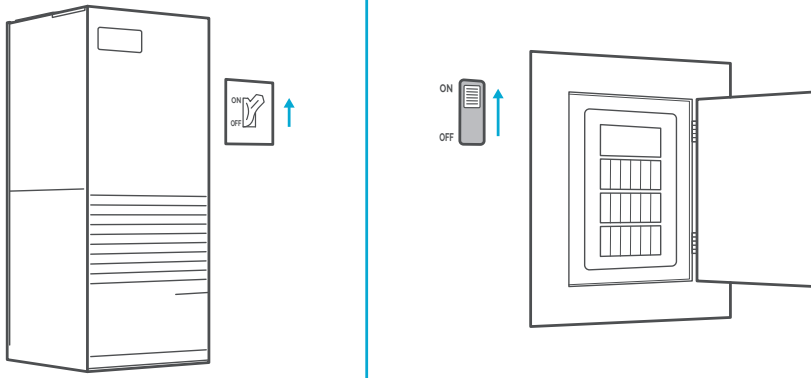

## **Installation Complete!**

Continue to the next page for steps to register your thermostat.

# **Registering Your Thermostat via the Cielo Home App**

# Prior to Registration

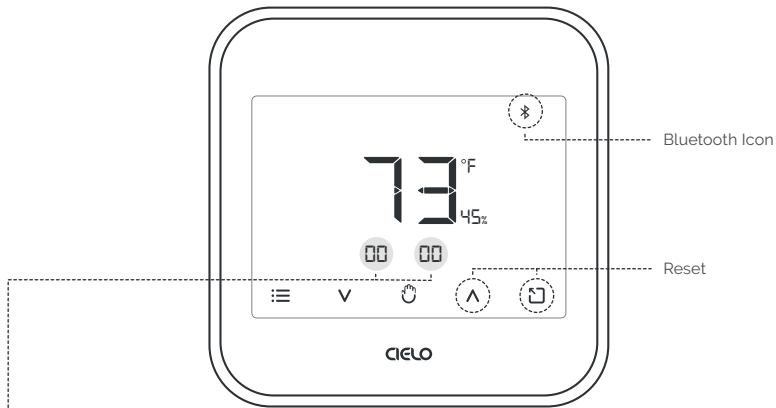

First, check that your **thermostat set points are 00**. If not, **press and hold the Temperature Up and Presets buttons simultaneously** until all the buttons vanish. **The Bluetooth icon will start blinking**, and you can begin the registration process.

## Prior to App Installation



- Make sure your smartphone's **Bluetooth is turned ON.**
- Make sure your smartphone's **Wi-Fi is turned ON.**
- Make sure your **smartphone has internet access.**

- Make sure you have a **working internet connection** on your Wi-Fi router.
- Make sure **there is no proxy server or authentication server configured** on your internet connection.
- Make sure **there is no captive portal** on your Wi-Fi router.

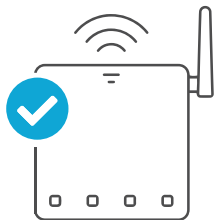

**Important:**

Make sure IP isolation or client isolation is turned OFF on your Wi-Fi router.

# App Installation & Registration

## iOS / Android

Install the 'Cielo Home' app from the App Store/Play Store. Search for the Cielo Home app or scan the QR code provided below.

Log in to the app if you already have an account; otherwise, create one using the **sign-up option**.

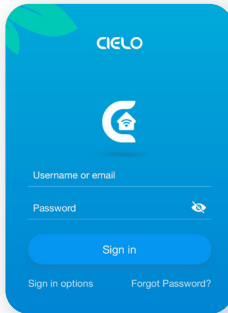
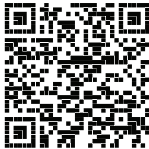

## Note for iOS users:

- For iOS 13.0 & above, **location permission is required to complete the registration process**. You may disable it later.

## Note for Android users:

- For Android OS 8.1 & above, **location permission is required to complete the registration process**. You may disable it later.

# Device Registration

## iOS / Android

Open the Cielo Home app, **tap 'Add Device' on the home screen, and select Thermostat Eco** from the list of devices.

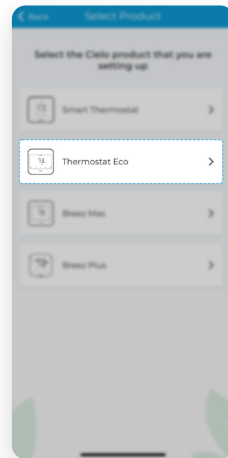
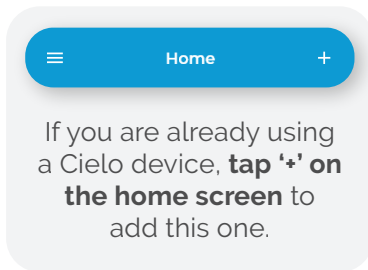
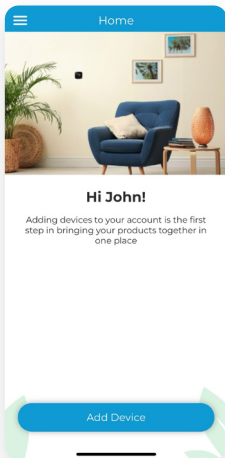



Tap **'Continue'** to start the registration process.

Please give necessary permissions and **tap 'Continue'**, your thermostat will appear on the screen.

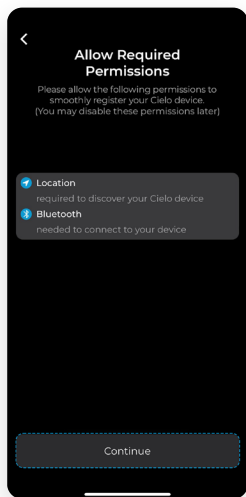

**Follow the on-screen instructions** to link your Thermostat Eco with the Cielo Home app.

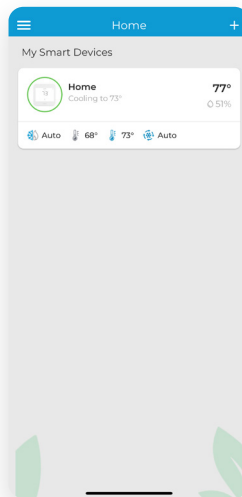
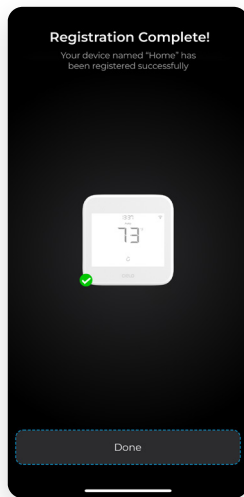

**After the registration process is complete, tap 'Done', and your Thermostat Eco will appear on the Home Screen.**

# Enjoy Unlimited Functionalities

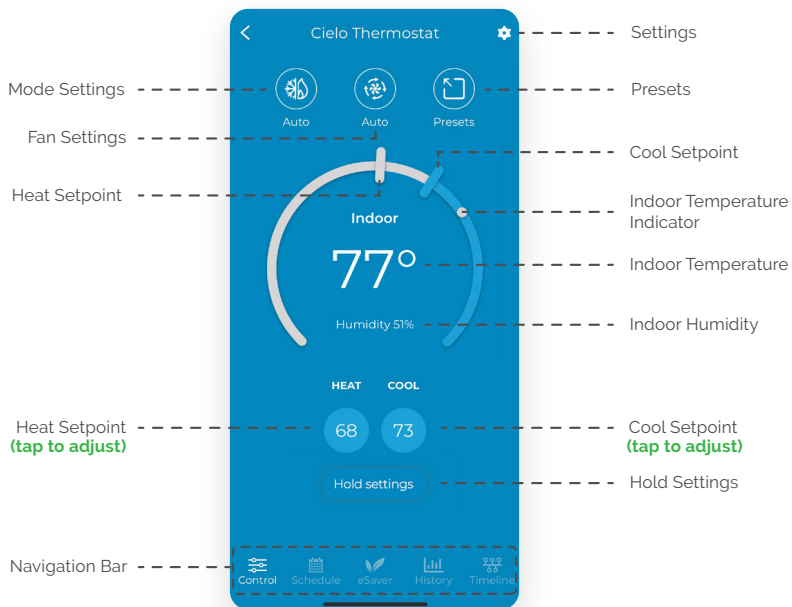

# Troubleshooting

If your Cielo Smart Thermostat Eco doesn't turn on, please try these steps:

1. Close your HVAC panel properly, as some systems may not work if the panel isn't fully closed.
2. Check the backplate wire connections and ensure they are inserted properly into the terminals.
3. In the case of one R-Wire, make sure it is inserted into the R<sub>c</sub> terminal.
  - R or R<sub>c</sub> or R<sub>H</sub> → R<sub>c</sub>

In case of more than one R-Wire, make sure R<sub>H</sub> is inserted into the R<sub>H</sub> terminal and R<sub>c</sub> or R is inserted into the R<sub>c</sub> terminal.

4. If you installed the C-Wire Adapter, ensure all wires are connected to the correct terminals on your thermostat.
  - R or R<sub>c</sub> → R<sub>c</sub>
  - G → C
  - Y/Y1 → CWA

## Need Help?

**Call:** +1 (425) 529-5775

**Email:** [support@cielowigle.com](mailto:support@cielowigle.com)

# On-Device Display

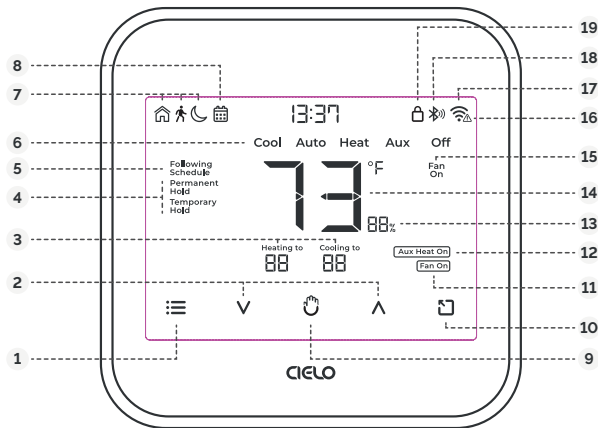

- |   |  |   |
|---|--|---|
| <b>1.</b> Menu Button                   | <b>8.</b> Schedule Set Indicator       | <b>14.</b> Indoor Temperature           |
| <b>2.</b> Temperature Up & Down Buttons | <b>9.</b> Wake Up/Hold Settings Button | <b>15.</b> Fan Settings                 |
| <b>3.</b> Setpoint Temperatures         | <b>10.</b> Presets Button              | <b>16.</b> No Internet Access           |
| <b>4.</b> Hold Status                   | <b>11.</b> Fan Running Indicator       | <b>17.</b> Wi-Fi Indicator              |
| <b>5.</b> Following Schedule Indicator  | <b>12.</b> Auxiliary Heat Indicator    | <b>18.</b> Bluetooth Indicator          |
| <b>6.</b> Modes                         | <b>13.</b> Indoor Humidity             | <b>19.</b> Screen Lock/Unlock Indicator |
| <b>7.</b> Active Preset Indicator       |  |   |

# On-Device Controls

## **Changing the mode of your HVAC system:**

Touch the menu button once. The modes will start blinking. Use the up or down button to select the mode (i.e., Cool, Heat, etc.).

## **Changing the fan settings:**

Touch the menu button twice. The fan settings icon will start blinking. Use the up or down button to change the fan settings (i.e., On, Auto).

## **Locking/Unlocking the display interface:**

Touch and hold the Temperature Up and Down buttons simultaneously until the lock icon on the top right of the screen turns solid or disappears.

## **Resetting the Wi-Fi of Smart Thermostat Eco:**

Touch and hold the Temperature Up and Hold Settings buttons simultaneously until the Wi-Fi icon disappears, and the Bluetooth icon starts blinking.

## **Wi-Fi Icon:**

**Case 1:-** Stable Wi-Fi icon - Device is connected to the internet, showing Wi-Fi strength.

**Case 2:-** Wi-Fi icon with small triangle - Device is connected to the router but has no internet access. Please ensure you have a working internet connection and restart the device.

## **Bluetooth Icon:**

Blinking Bluetooth icon - Device is in broadcast (AP) mode. Please complete the registration process.

# LIMITED WARRANTY & END USER LICENSE AGREEMENT

## 1. WHAT IS COVERED?

Cielo WiGLE, Inc. ("Cielo"), warrants to the owner of the Cielo product contained in this box (the "Product") that the Product will be free from defects in materials and workmanship for a period of three years from the date of delivery following the original retail purchase (the "Warranty Period"). If the Product is installed by a licensed HVAC Pro, the Warranty Period will be extended to five (5) years from the date of installation. If the Product fails to conform to this Limited Warranty during the Warranty Period, Cielo will, at its sole discretion, either (a) repair or replace the defective Product or component; or (b) accept the return of the Product and refund the money actually paid by the original purchaser for the Product. Repair or replacement may be made with a new or refurbished product or components, at Cielo's sole discretion. If the Product or a component incorporated within it is no longer available, Cielo may, at Cielo's sole discretion, replace the Product with a similar product having similar functions. This is your sole and exclusive remedy for breach of this Limited Warranty. Any Product that has either been repaired or replaced under this Limited Warranty will be covered by the terms of this Limited Warranty for the longer of (a) ninety (90) days from the date of delivery of the repaired Product or replacement Product, or (b) the remaining Warranty Period. This Limited Warranty is transferable from the original purchaser to subsequent owners, but the Warranty Period will not be extended in duration or expanded in coverage for any such transfer.

## 2. RETURN POLICY

If you are the original purchaser of the Product and you are not satisfied with this Product, you may return it in its original condition within thirty (30) days of the original purchase and receive a full refund.

## 3. WARRANTY CONDITIONS

Before making a claim under this Limited Warranty, the owner of the Product must (a) visit [cielowigle.com/support](http://cielowigle.com/support) during the Warranty Period to provide notice of your warranty claim and describe the alleged failure, and (b) comply with Cielo's (or its authorized distributor's) return shipping instructions. Cielo will have no warranty obligations with respect to a returned Product if it determines, in its reasonable discretion after examination of the returned Product, that the Product is an Ineligible Product (defined below).

## 4. WHAT THIS LIMITED WARRANTY DOES NOT COVER

This Limited Warranty does not cover the following (collectively "Ineligible Products"): (i) Products marked as "sample" or "Not for Sale", or sold "AS IS"; (ii) Products that have been subject to: (a) modifications, alterations, tampering, or improper maintenance or repairs, except if performed by Cielo; (b) handling, storage, installation, testing, or use not in accordance with any User's Guide, Placement Guidelines, or other instructions provided by Cielo; (c) abuse or misuse of the Product; (d) breakdowns, fluctuations, or interruptions in electric power or the telecommunications network; or (e) Acts of God, including but not limited to lightning, flood, tornado, earthquake, or hurricane; or (iii) any non- Cielo branded hardware products, even if packaged or sold with Cielo hardware. This Limited Warranty does not cover consumable parts, including batteries, unless damage is due to defects in materials or workmanship of the Product, or software (even if packaged or sold with the product). Cielo recommends that you use only authorized service providers for maintenance or repair. Unauthorized use of the Product or software can impair the Product's performance and may invalidate this Limited Warranty.....

**For detailed information on warranty, please visit:**

[cielowigle.com/legal](http://cielowigle.com/legal)

For any queries, please visit:  
**cielowigle.com**

OR

Call: **+1 (425) 529-5775**  
Email: **support@cielowigle.com**

**Cielo WiGle Inc., Bellevue, WA, USA**  
All rights reserved.