

Cielo Smart Thermostat

Installation Manual



Cielo Smart Thermostat is designed and optimized to save energy while prioritizing comfort.

Simple to Install | Easy to Use | Saves Energy

Let's Get Started!



Tools you need:

Drill for mounting anchors (3/16" drill bit)

Small flathead screwdriver

Phillips screwdriver

Wire stripper (optional)

Hammer (optional)

Pencil (optional)

Included in the box:



Cielo Smart Thermostat

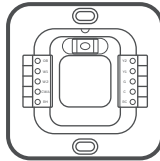

Thermostat Backplate

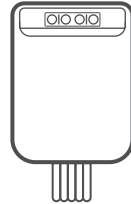

C-Wire Adapter

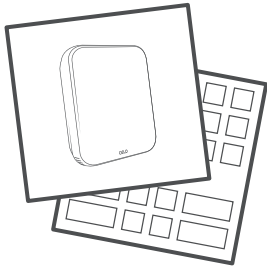

Installation Manual
and Wire Labels

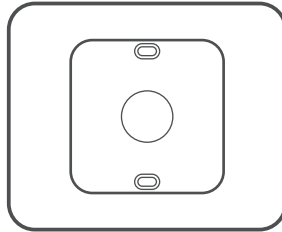

Thermostat Wall Plate

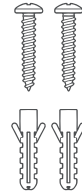

Mounting Screws With
Drywall Anchors

Getting Help

No long queues, no bots, no delays.
We answer 98% calls in less than 2 minutes
and guarantee that you will **talk to a REAL person.**

Visit our website: cielowigle.com and
select support to access user guides.



Email us at:
support@cielowigle.com

Call us at:
+1 (425) 529-5775

9 AM - 9 PM ET, Mon-Fri

Note: The information and instructions in this manual are subject to change. For the latest details, please visit support.cielowigle.com



Let's Install the Thermostat

Step 1:

Safety First - Power off the HVAC system using:

- 1 The master switch
OR
- 2 The circuit breaker

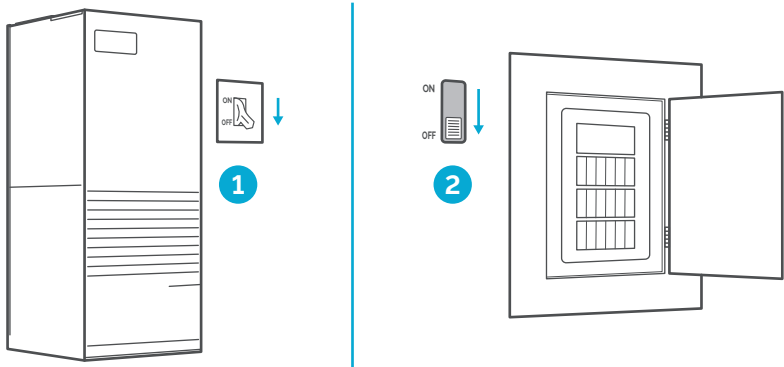

Step 2:

To be on the safe side, **ensure that the system is completely switched off**. Double-check that:

- 1 No air is coming out of the air vents.

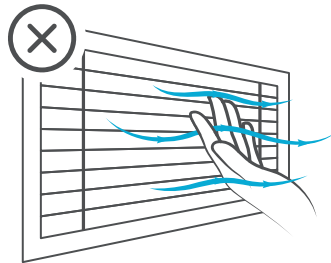
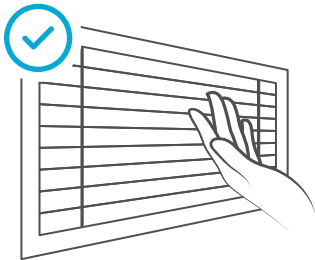

- 2 Main flame is extinguished in the case of a boiler.

Step 3:

Go to the already installed thermostat and **remove it** from the wall.

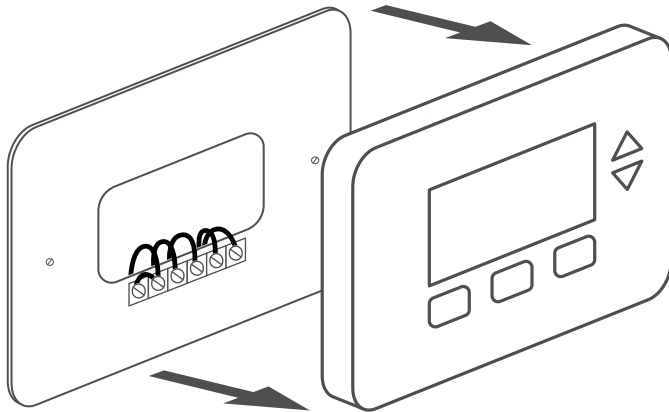

Step 4:

Look closely for any of the following indicators on the old thermostat's backplate:

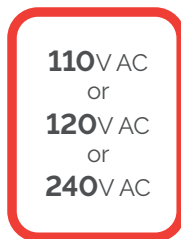
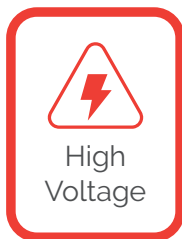
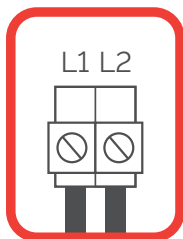

If you find any of the above indicators, please contact Cielo Tech Support for assistance (visit page 4 for contact details).

In case of no such indicators, go to the next page.

⚠ WARNING

Cielo Smart Thermostat only works with 24V AC.
It does not work with line (high) voltage or millivolt systems.

Step 5:

Grab your smartphone and **take a picture** of the old thermostat wiring.

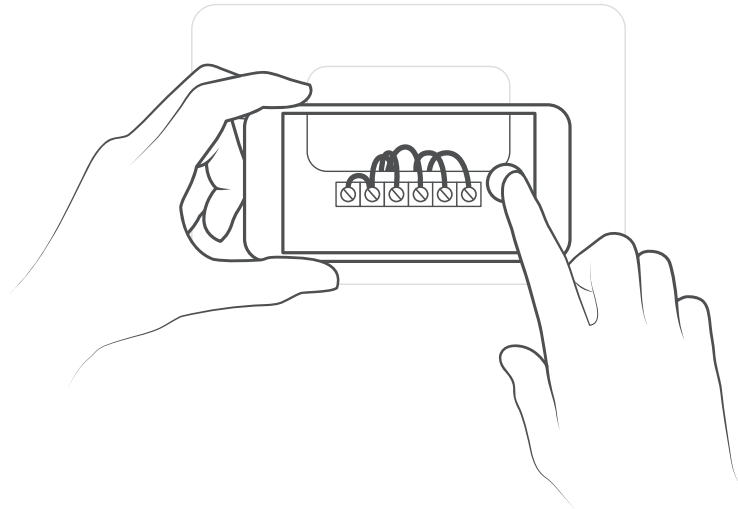

Step 6:

Does the old thermostat have a
C-Wire connection?

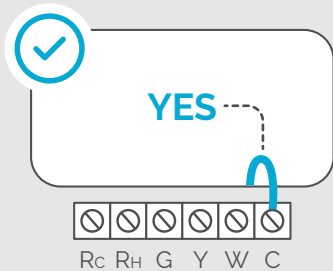

Continue to **Section 1**
on the next page

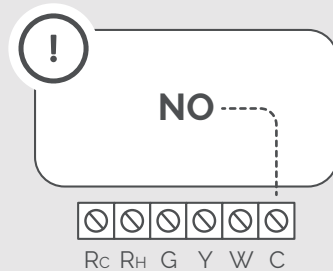

Continue to **Section 2**
on page 22

Section 1

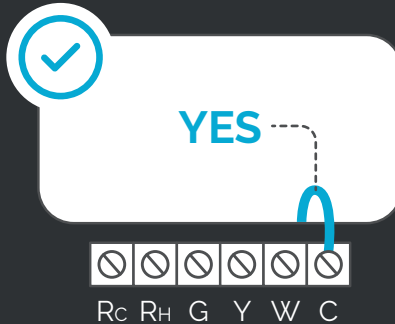

Installing Cielo Smart Thermostat With a C-Wire

Step 7:

- 1 **Disconnect the old thermostat wires** one by one and mark them using the wire labels (included in the box).

Jumper wire is not required with the new thermostat.

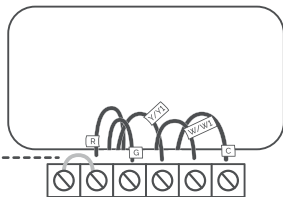

- 2 Remove the mounting plate of the old thermostat.

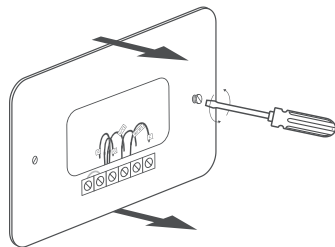

Step 8:

Optional: You may use the provided wall plate to hide any marks or holes on the wall left by the old thermostat installation.

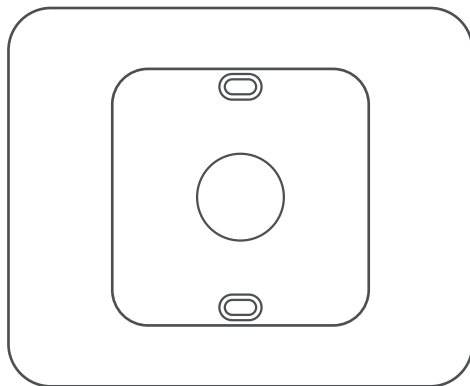

Step 9:

- 1 Take out the labeled wires through the hole in the middle of the Cielo Smart Thermostat backplate.
- 2 Screw in the backplate using the provided pair of drywall anchors and screws.

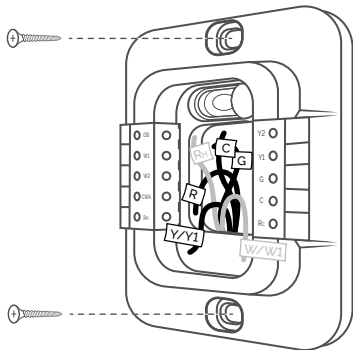

Step 10(A):

Do you have more than one R-Wire?
(That includes R, R_c, and R_H)

✓ YES

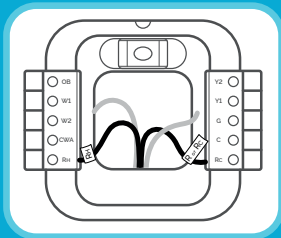

Insert the wires:
RH → RH R or R_c → R_c

⊗ NO

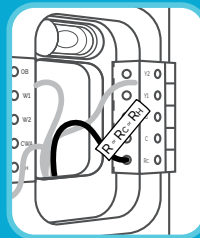

Insert the single
R, R_c, or R_H wire into
the R_c terminal.

Step 10(B):

Do you want to connect an accessory
(humidifier or dehumidifier) to the thermostat?

1-wire accessory

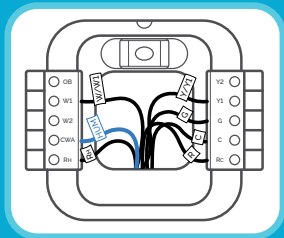

Insert the **HUM** or **DHUM** wire
into the **CWA Terminal**.

2-wire accessory

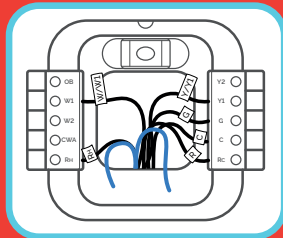

**A 24V AC isolation relay is
required to install a 2-wire accessory.
Please contact Cielo Tech
Support for assistance.**

Call: **+1 (425) 529-5775**

Email: **support@cielowigle.com**

Step 11:

Insert the remaining wires into their corresponding terminals from the side (press terminal block buttons for ease of insertion).

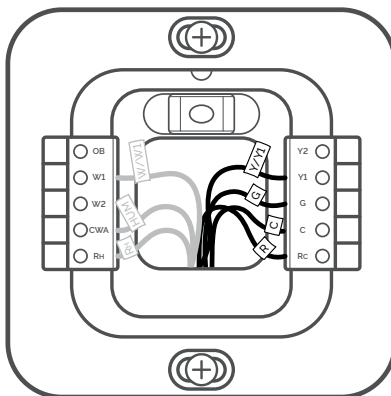

Step 12:

Gently push the excessive wires back into the wall hole to ensure that no drafts are coming from it.

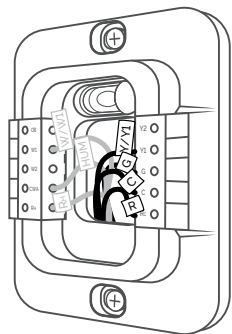
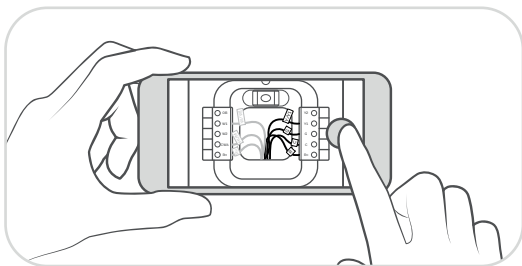

Take a picture of the backplate.
You may need it at the time of registration.

Step 13:

Align the **Cielo Smart Thermostat** with the backplate and press gently to **fix it properly**.

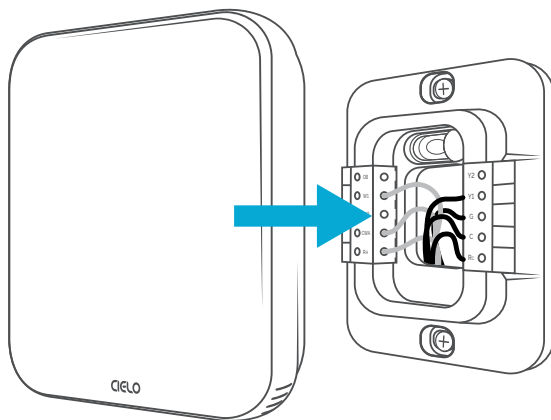

Step 14:

Go to the HVAC system and turn on the power from the master switch or circuit breaker.

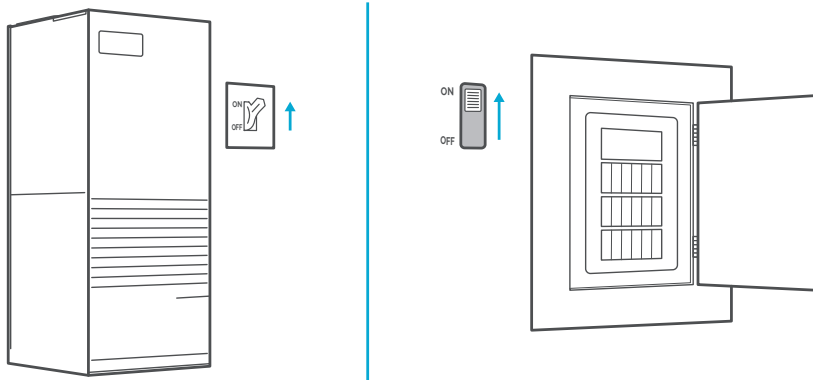

Installation Complete!

Go to **page 41** for steps to register the thermostat.

Section 2

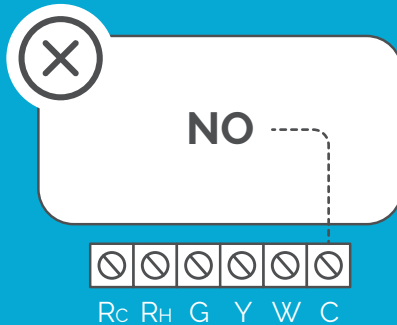

Installing Cielo Smart Thermostat Without a C-Wire

If the system has any of the following wires,
it should work with the C-Wire Adapter.

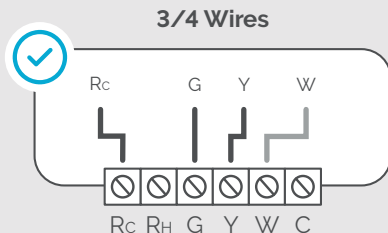
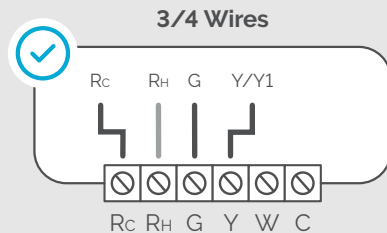
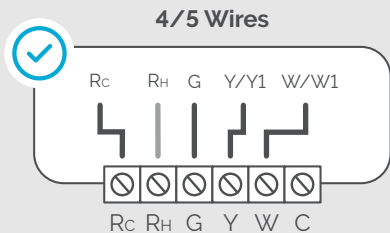

Please continue on page 25

If the system has these wires:

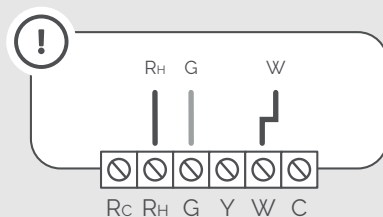

**Contact Cielo Tech Support;
we will help you with the installation.**



Email us at: support@cielowigle.com

Call us at: **+1 (425) 529-5775**

9 AM - 9 PM ET, Mon-Fri

Step 7:

Take out **the C-Wire Adapter (CWA)** from the Cielo Smart Thermostat box.

(Ensure that you have already completed steps 1-5 of this guide)

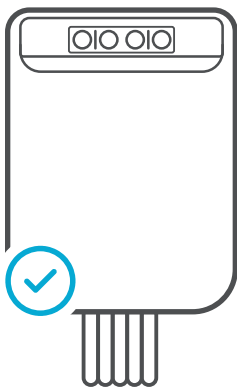

Step 8:

Grab the CWA, wire labels, tools, your smartphone, and **go to the HVAC system.**

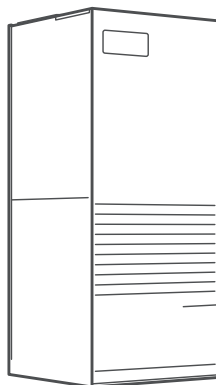

Step 9:

Take off the HVAC system's cover to **access the control board and take a picture of the connected wires.** You may need it at a later stage.

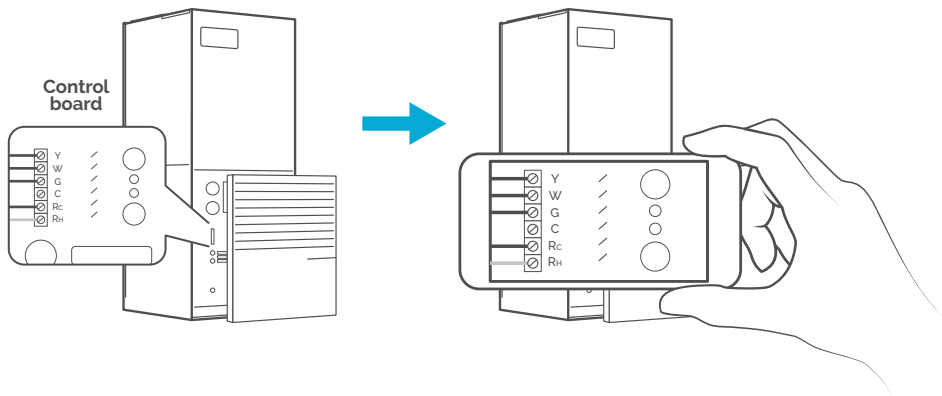

WARNING

Proceed with caution, as HVAC systems contain high-voltage wires.

Step 10:

Label only the following wires with the matching labels:

R - **Y or Y1** - **G** - **W or W1**

You only need to label the wires coming from the thermostat.

Ignore any extra wires going into the terminals.

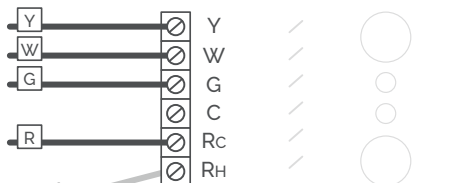

Note:

In the case of a two-transformer system (wires connected to both Rc and Rh terminals at the control board), please contact Cielo Tech Support to help you with the installation. **Call:** +1 (425) 529-5775 **Email:** support@cielowigle.com

Step 11:

Disconnect the labeled **R, Y, G,** and **W** wires from the control board.

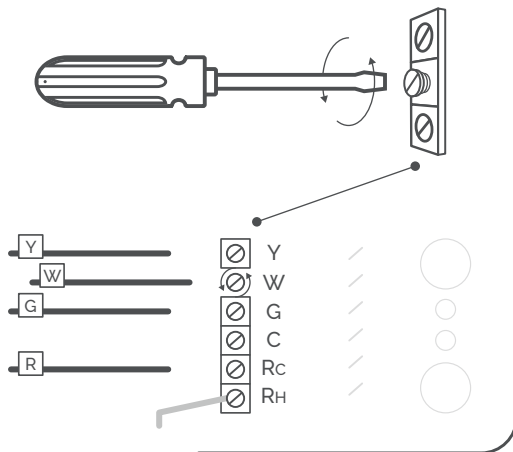

Step 12:

Securely connect the wires from the control board
to their matching terminals on the CWA.

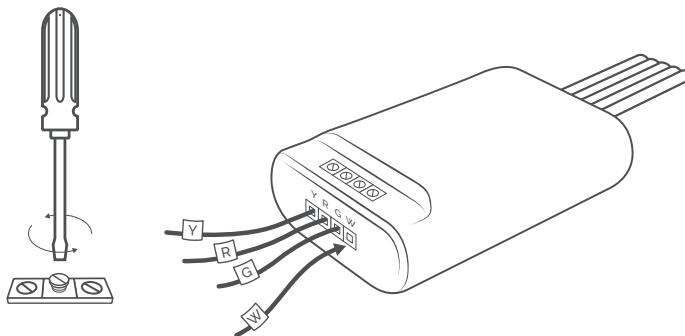

Step 13:

Securely connect all the wires coming out of the CWA to the corresponding terminals on the **control board** of the HVAC system.

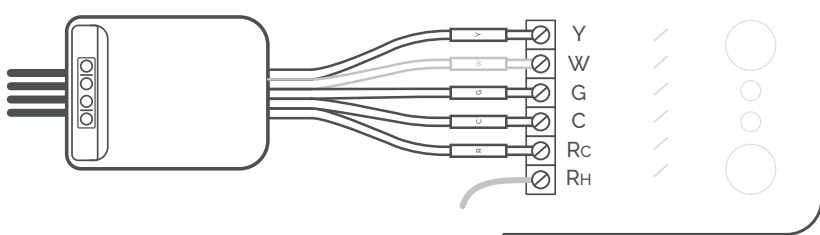

Step 14:

Place/mount the CWA at a suitable location inside the HVAC system. Close the HVAC cover panel securely and **return to the old thermostat.**

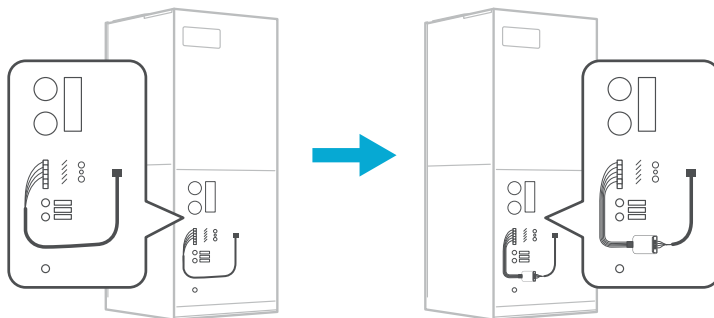

Step 15:

- 1 **Disconnect the old thermostat wires** one by one and mark them using the wire labels (included in the box).

Jumper wire is not required with the new thermostat.

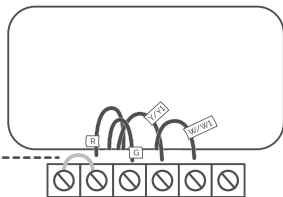

- 2 Remove the mounting plate of the old thermostat.

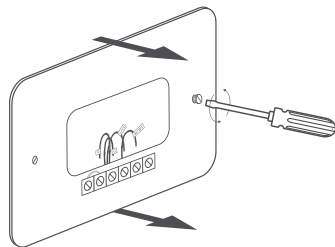

Step 16:

Optional: You may use the provided wall plate to hide any marks or holes on the wall left by the old thermostat installation.

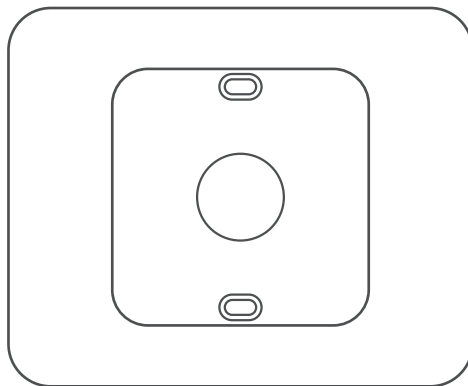

Step 17:

- 1 Take out the labeled wires through the hole in the middle of the Cielo Smart Thermostat backplate.
- 2 Screw in the backplate using the provided pair of drywall anchors and screws.

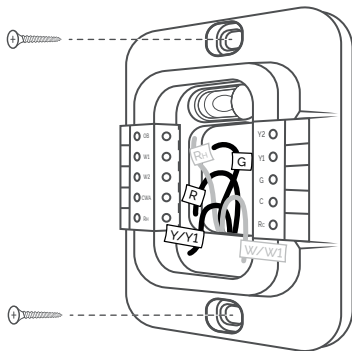

Step 18(A):

First, connect these 3 wires as shown:

R/Rc → **Rc**

G → **C**

Y/Y1 → **CWA**

Then, connect the remaining wires to their corresponding terminals (press terminal block buttons for ease of insertion).

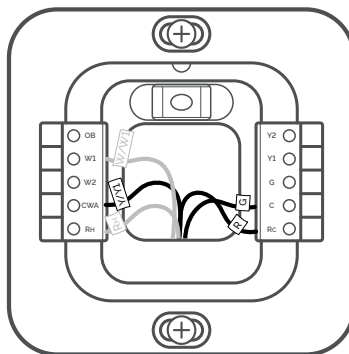

Step 18(B):

Do you want to connect an accessory
(humidifier or dehumidifier) to the thermostat?

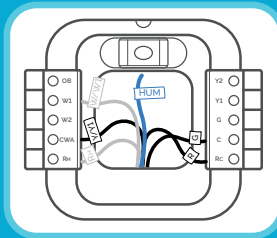

Contact Cielo Tech Support
for Assistance

Call: +1 (425) 529-5775
Email: support@cielowigle.com

Step 19:

Gently push the excessive wires back into the wall hole to ensure that no drafts are coming from it.

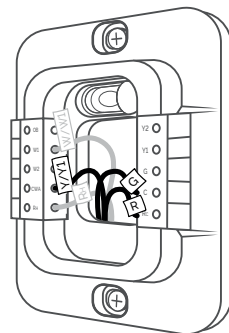
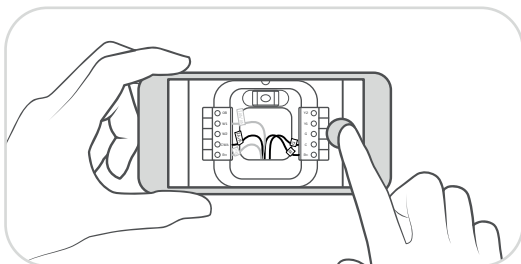

Take a picture of the backplate.
You may need it at the time of registration.

Step 20:

Align the **Cielo Smart Thermostat** with the backplate and press gently to **fix it properly**.

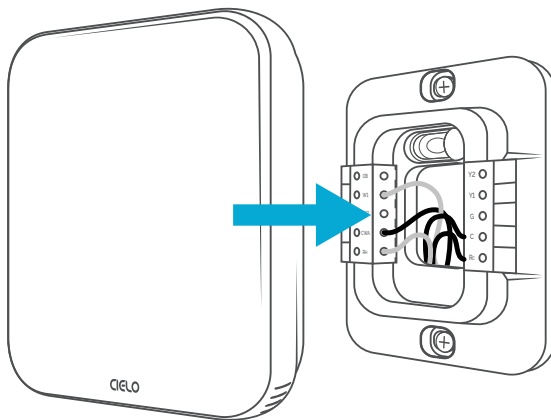

Step 21:

Go to the HVAC system and turn on the power from the master switch or circuit breaker.

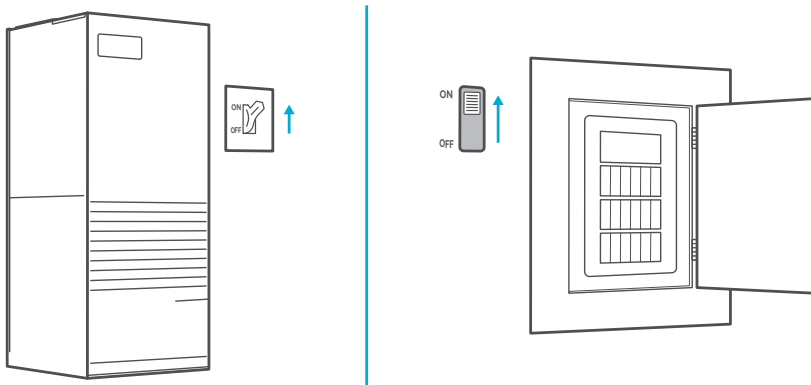

Installation Complete!

Continue on the next page for steps to register the thermostat.

Registering the Thermostat

On-Device Registration

Tap on '**Continue here**' and follow the on-screen instructions to register the thermostat.

(Can also be registered without Wi-Fi)



On-Device Registration

- 1 The thermostat will display the connected wires. Tap **'Next'**.
(Or tap **'Modify'** for manual configuration).

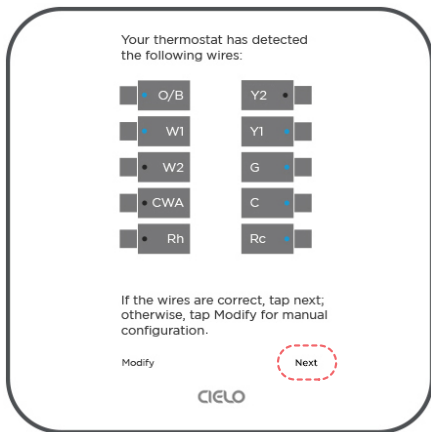

Follow the on-screen instructions to register the thermostat.

On-Device Registration (Cont'd)

- 2 Choose how the temperature should be displayed. Tap **'Next'**.
- 3 Name the thermostat. Tap **'Next'**.
- 4 Set the HVAC mode and preferred heating and cooling temperature. Tap **'Next'**.



On-Device Registration (Cont'd)

- 5 Connect the thermostat to Wi-Fi.
Skip this step if you want to register the thermostat without Wi-Fi.



On-Device Registration (Cont'd)

- 6 Select the country and time zone.

Select your country

United States

Canada

Mexico

Back

CIELO

Select your time zone

New York

Chicago

Denver

Phoenix

Los Angeles

Anchorage

Back

CIELO

On-Device Registration (Cont'd)



✔ Registration is now complete.

Testing the HVAC System

The Test Equipment feature allows you to test the heating, cooling, fan, or connected accessories to confirm that the HVAC system is working properly.

- 1 Tap the '**Menu**' icon and go to '**HVAC Settings**'.

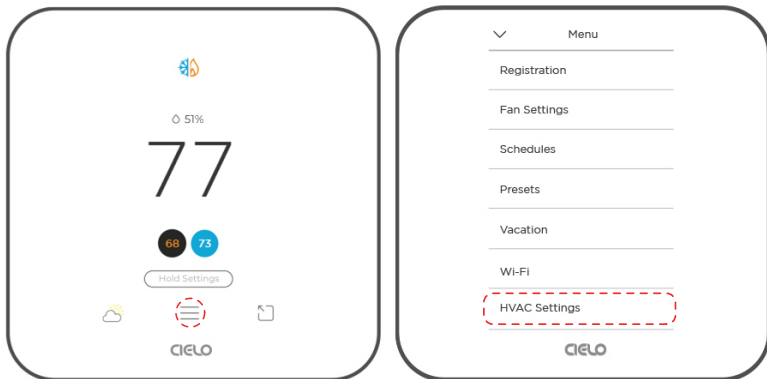

Testing the HVAC System (Cont'd)

- 2 Tap on **'Test Equipment'**. You will find the various system functions available for testing. Select the function you wish to test.

Note: The options displayed on the Test Equipment screen will vary based on the configured equipment.

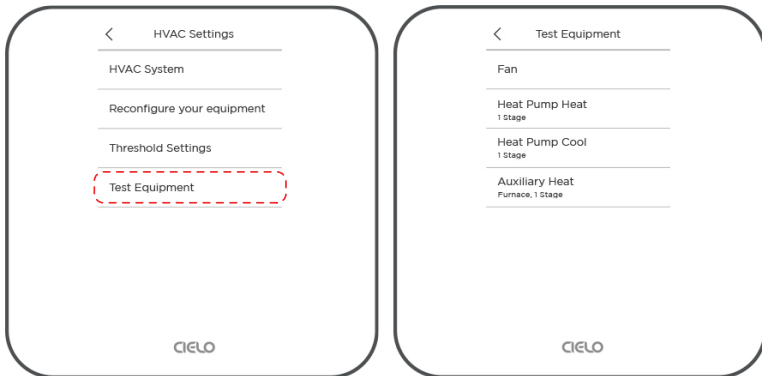

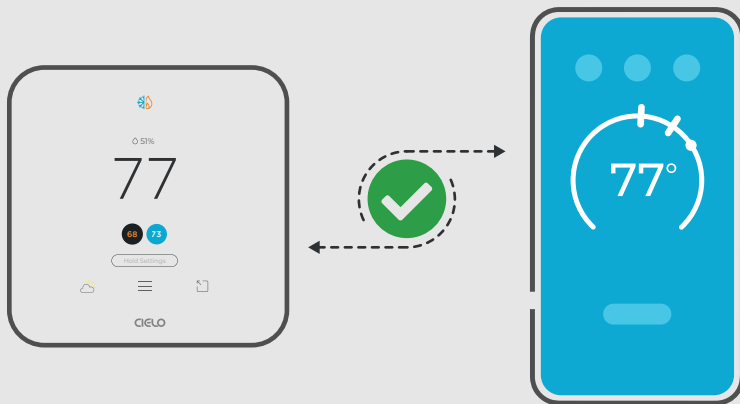

Connecting Your Thermostat to the Cielo Home App

Prior to App Installation



- Make sure that smartphone's **Bluetooth is turned ON.**
- Make sure that smartphone's **Wi-Fi is turned ON.**
- Make sure that **smartphone has internet access.**

- Make sure the Wi-Fi router **has working internet connection.**
- Make sure **there is no proxy server or authentication server configured** on the internet connection.
- Make sure **there is no captive portal** on the Wi-Fi router.

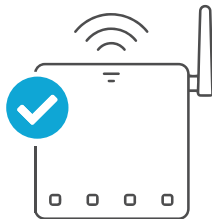

Important:

Make sure IP isolation or client isolation is turned OFF on the Wi-Fi router.

App Installation & Registration

iOS / Android

Install the 'Cielo Home' app from the App Store/Play Store. Search for the Cielo Home app or scan the QR code provided below.

Log in to the app if you already have an account; otherwise, create one using the **sign-up option**.

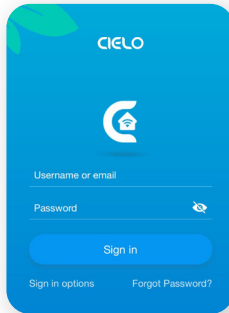
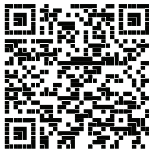

Note for iOS users:

- For iOS 13.0 & above, **location permission is required to complete the registration process**. You may disable it later.

Note for Android users:

- For Android OS 8.1 & above, **location permission is required to complete the registration process**. You may disable it later.

Connecting Your Thermostat to the Cielo Home App

Open the Cielo Home app, **tap 'Add Device' on the home screen, and select Smart Thermostat** from the list of devices.

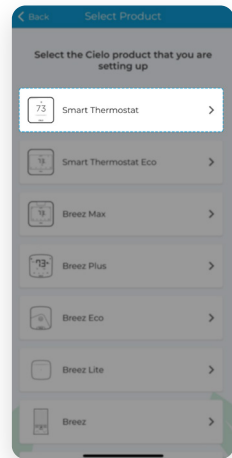
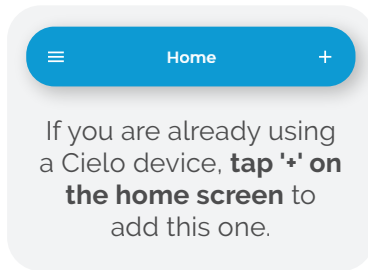
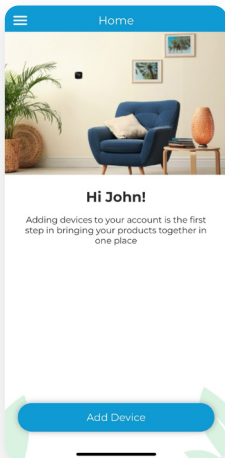

Connecting Your Thermostat to the Cielo Home App (Cont'd)

Tap '**Continue**' to link your thermostat to the Cielo Home app.
Please give necessary permissions and tap '**Continue**'.

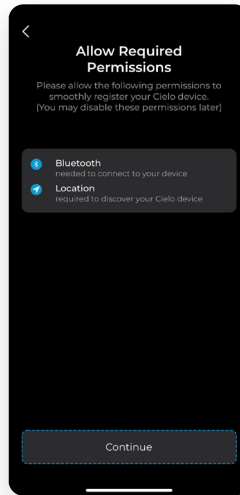

Connecting Your Thermostat to the Cielo Home App (Cont'd)

- 1 Go to your thermostat.

Note: Make sure the **thermostat is connected to Wi-Fi** before proceeding.

- 2 Tap on the '**Menu**' icon.
- 3 Select '**Registration**'.

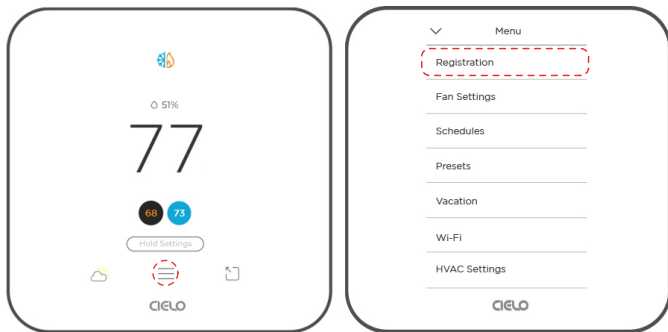

Connecting Your Thermostat to the Cielo Home App (Cont'd)

- 4 Tap on 'Get Registration Code'.

Note: You will be presented with a unique six-digit code that will be valid for the next 30 minutes.

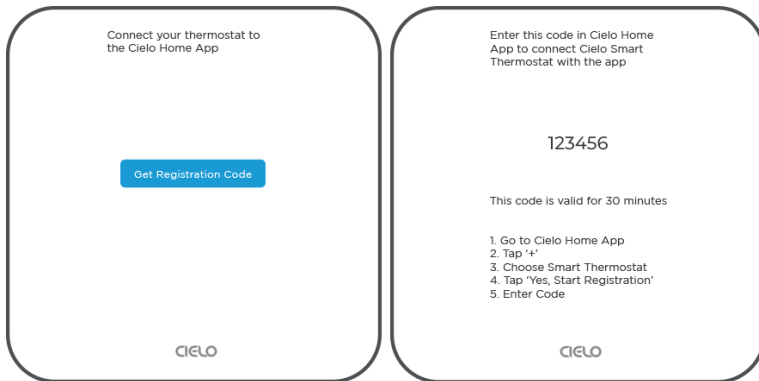

Connecting Your Thermostat to the Cielo Home App (Cont'd)

Enter the six-digit code in the Cielo Home app and tap **'Verify'**.

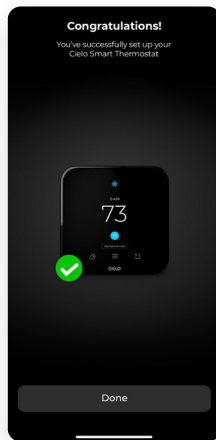

Your thermostat has been successfully connected to the Cielo Home app.

Cielo Home App Control Screen

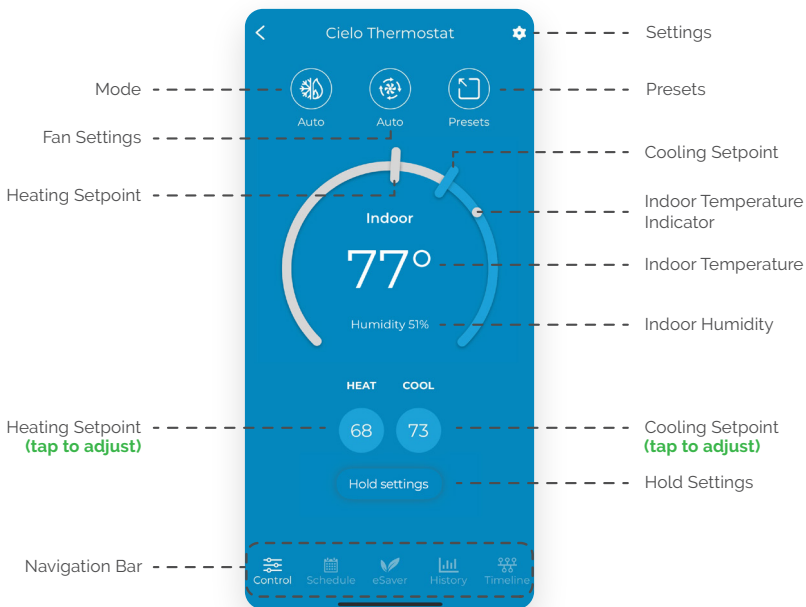

Troubleshooting

If the Cielo Smart Thermostat doesn't turn on, please try these steps:

1. Close the HVAC panel properly, as some systems may not work if the panel isn't fully closed.
2. Check the backplate wire connections and ensure they are inserted properly into the terminals.
3. In the case of one R-Wire, make sure it is inserted into the R_c terminal.
 - R or R_c or R_H → R_c

In case of more than one R-Wire, make sure R_H is inserted into the R_H terminal and R_c or R is inserted into the R_c terminal.

4. If you installed the C-Wire Adapter, ensure all wires are connected to the correct terminals on the thermostat.
 - R or R_c → R_c ● G → C ● Y/Y1 → CWA

5. In case of dual power source i.e., R_c & R_H, power the accessory (humidifier or dehumidifier) using the cooling system's power source i.e., R_c and C. **DO NOT use the heating system's power source i.e., R_H & C, as it may damage the equipment.**

Cielo Smart Thermostat Control Screen

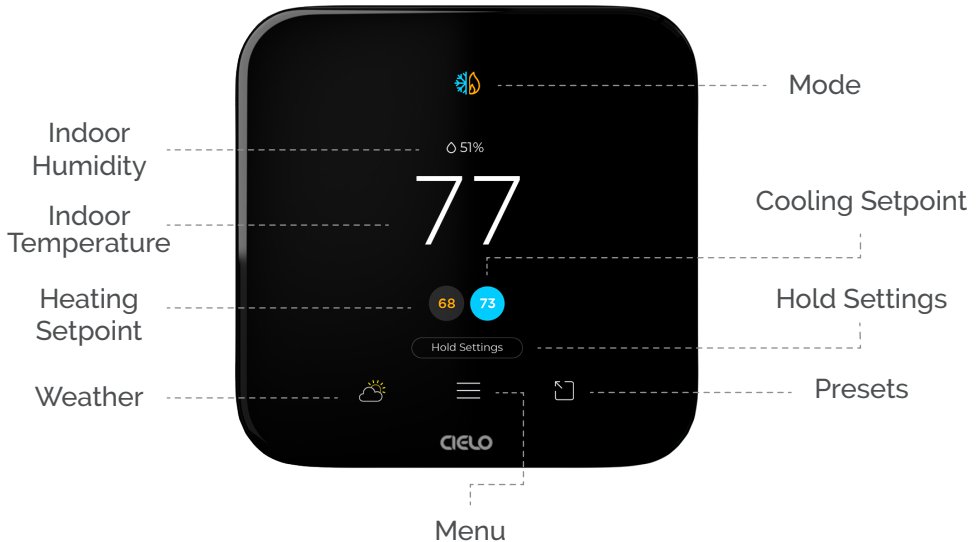

Cielo Smart Thermostat Control Screen (Cont'd)



Mode

Indicates the current thermostat settings (**Heat/Cool/Auto/AUX/Off**). Tap on the mode icon to select the preferred mode.



Menu

Allows to set schedules, system settings, device preferences, and more.



Indoor Humidity

Displays the current indoor humidity levels.



Presets

Gives quick access to Presets - Home, Away, Pets, and Sleep.



Indoor Temperature

Displays the current indoor temperature.



Setpoint

Desired temperature the HVAC system aims to achieve.



Weather

Shows current weather and weekly forecast.



Hold Settings

Holds the current thermostat settings.

Note: In case of an internet outage, Cielo Smart Thermostat saves 72 hours of weather data to execute your predefined weather based actions, ensuring uninterrupted home comfort.

LIMITED WARRANTY & END USER LICENSE AGREEMENT

1. WHAT IS COVERED?

Cielo WiGLE, Inc. ("Cielo"), warrants to the owner of the Cielo product contained in this box (the "Product") that the Product will be free from defects in materials and workmanship for a period of three years from the date of delivery following the original retail purchase (the "Warranty Period"). If the Product is installed by a licensed HVAC Pro, the Warranty Period will be extended to five (5) years from the date of installation. If the Product fails to conform to this Limited Warranty during the Warranty Period, Cielo will, at its sole discretion, either (a) repair or replace the defective Product or component; or (b) accept the return of the Product and refund the money actually paid by the original purchaser for the Product. Repair or replacement may be made with a new or refurbished product or components, at Cielo's sole discretion. If the Product or a component incorporated within it is no longer available, Cielo may, at Cielo's sole discretion, replace the Product with a similar product having similar functions. This is your sole and exclusive remedy for breach of this Limited Warranty. Any Product that has either been repaired or replaced under this Limited Warranty will be covered by the terms of this Limited Warranty for the longer of (a) ninety (90) days from the date of delivery of the repaired Product or replacement Product, or (b) the remaining Warranty Period. This Limited Warranty is transferable from the original purchaser to subsequent owners, but the Warranty Period will not be extended in duration or expanded in coverage for any such transfer.

2. RETURN POLICY

If you are the original purchaser of the Product and you are not satisfied with this Product, you may return it in its original condition within thirty (30) days of the original purchase and receive a full refund.

3. WARRANTY CONDITIONS

Before making a claim under this Limited Warranty, the owner of the Product must (a) visit cielowigle.com/support during the Warranty Period to provide notice of your warranty claim and describe the alleged failure, and (b) comply with Cielo's (or its authorized distributor's) return shipping instructions. Cielo will have no warranty obligations with respect to a returned Product if it determines, in its reasonable discretion after examination of the returned Product, that the Product is an Ineligible Product (defined below).

4. WHAT THIS LIMITED WARRANTY DOES NOT COVER

This Limited Warranty does not cover the following (collectively "Ineligible Products"): (i) Products marked as "sample" or "Not for Sale," or sold "AS IS"; (ii) Products that have been subject to: (a) modifications, alterations, tampering, or improper maintenance or repairs, except if performed by Cielo; (b) handling, storage, installation, testing, or use not in accordance with any User's Guide, Placement Guidelines, or other instructions provided by Cielo; (c) abuse or misuse of the Product; (d) breakdowns, fluctuations, or interruptions in electric power or the telecommunications network; or (e) Acts of God, including but not limited to lightning, flood, tornado, earthquake, or hurricane; or (iii) any non- Cielo branded hardware products, even if packaged or sold with Cielo hardware. This Limited Warranty does not cover consumable parts, including batteries, unless damage is due to defects in materials or workmanship of the Product, or software (even if packaged or sold with the product). Cielo recommends that you use only authorized service providers for maintenance or repair. Unauthorized use of the Product or software can impair the Product's performance and may invalidate this Limited Warranty.....

For detailed information on warranty, please visit:

cielowigle.com/legal

For any queries, please visit:
cielowigle.com

OR

Call: **+1 (425) 529-5775**
Email: **support@cielowigle.com**

Cielo WiGle Inc., Bellevue, WA, USA
All rights reserved.